

**AUDITORY SEISMOLOGY  
ON FREE OSCILLATIONS, FOCAL MECHANISMS, EXPLOSIONS  
AND SYNTHETIC SEISMOGRAMS**

*Florian Dombois*

Fraunhofer Institute Media Communication  
Schloss Birlinghoven  
D-53754 St. Augustin, Germany  
dombois@gmd.de

**ABSTRACT**

The method of audifying seismograms and interpreting seismological data by ear enables a wide range of geophysical questions to be studied in a new manner. In this article we report about the actual state of research in Auditory Seismology. Some tests were carried out in the area of free oscillation phenomena, focal mechanisms of earthquakes, explosion signals and synthetic seismograms. The results confirm the difference between visual and acoustic approach as having different foci: Free oscillations as a phenomenon of resonance are easily accessible for the ear, whereas synthetic seismograms give acoustically less insight than visually. Beyond the seismological investigation the article gives a historical introduction of Auditory Seismology up to the present, and a summary of earlier results to contextualize these and assist the process of establishing the acoustical approach as an individual research field.

**1. FROM EARTHQUAKE SOUNDS TO  
AUDIFIED SEISMOGRAMS**

Not too often, but sometimes, earthquakes are accompanied by audible sounds. These sounds represent the high end of the earthquake's frequency spectrum and they sound like a low pitch rumbling from a far thunderstorm. Sound recordings of such events are rare and have been made nearly always accidentally. Karl V. Steinbrugge collected in 1974 a number of such recordings and published in the Bulletin of the Seismological Society a catalogue of his collection [1]. Interestingly he published not only the textual classification but also some of the sounds themselves. A little record album was made especially and attached to the journal; quite a rarity in scientific journals. Reports on sounds accompanying earthquakes date much older than the 1970's. Already in ancient literature descriptions of that noise can be found and this phenomenon has been quoted in descriptive texts throughout the centuries.

A technical recording of earthquake sounds became theoretically possible after 1878 when Edison invented the phonograph (even though I have not heard of any earthquake sound recordings before the 1950's). Edison's invention enabled not only the recording of real sounds, but also the production of artificial sounds. By playing

sounds from curves on a wax roll, a phonograph can open the ear to any curve: here the concept of audification first becomes thinkable. An early - maybe the earliest - example of the striking idea of drawn curves audified can be found in Rainer Maria Rilke's text "Ur-Geräusch" of 1919 [2]. Here he imagines how a "Kronen-Naht", i. e. the curve of a sutura coronalis on a skull, must be assumed to sound like.

The curve we are interested in is the seismogram, and it is fascinating to note that at the same time as when Edison developed his phonograph, there was also the first successful seismograph of low sensitivity invented by P. F. Cecchi in 1876 (Independently British scientists in Japan built seismographs in the 1880's and were very successful in measuring and calculating from these recordings. John Milne, James Ewing and Thomas Gray lay there the foundation of modern graphical seismology. Cf. [3]). If we imagine that early seismologists had used wax rolls for their seismic recordings like the ones of Edison's phonograph, they might have switched the rolls between the instruments, and thus listening to the ground's motion would have been invented more than a hundred years ago. But it took until the early 1960's before the first seismologists brought together the power of seismometers, phonographs and the idea of audification to listen to seismic records. These days seismologists used regular audio tape to store the recordings of their seismometers and started - probably inspired by the medium - to play these tapes on an audio speaker.

Stationers listened to the data first, I have been told, for entertainment, but then figured out that this method is valuable for detecting signals of seismic events. Especially, distant earthquakes with low frequencies are mostly hidden in noise and picking arrival times is often more difficult in the visual display than in the auditory. The first published paper on audifying seismic recordings was "Seismometer Sounds" by S. D. Speeth in 1961 [4] where he tested audification for signal discrimination between natural quakes and atomic explosions. G. E. Frantti and L. A. Leverault [5] did a second survey on this topic but only proved a success rate of 67.5 % for a discrimination between natural and man made signals. Audification in seismology was then neglected until Chris Hayward brought up the topic in his ICAD paper delivered in 1992 [6]. Cooperating closely with Gregory Kramer he did an extensive and diligent investigation of the topic and was first to examine the overall potential of

audification in the area of seismics and seismology. In his paper Hayward concentrated much on the single wavelet and quantitative questions. He also proposed audification as a promising approach, which unfortunately was not appreciated sufficiently by the geophysical community.

Several people redeveloped the idea of audification in seismology in the 1990's approaching from different sides: Frank Scherbaum, professor of geophysics at University of Potsdam, Germany, has a musical background and was fascinated by the idea of the earth as an instrument or sound body. Together with the composer Wolfgang Loos he audified series of seismograms and focussed much on volcano's seismic activity. They compiled and mixed the material in a music CD published in autumn 1999 [7]. - Speaking personally my motivation to listen to earthquake data was inspired by philosophical and cultural research on earthquake representations in different contexts [8]. The first presentation of the idea together with an sound example was presented at the exhibition "Hören und Sehen" in 1994 at the Academy of Arts in Berlin, Germany. The concept became part of my PhD thesis [8], caused further publications ([9], [10], [11]) and a website, installed with the intention to gather literature and activities and make it public for further distribution [12]. - Furthermore Cellini, Mariotti and Nucera, amateur seismologists from Italy, also proposed audification but for earthquake prediction. They published their results in 2000 and named it "Fonosismologia" [13]. - And last not least there are two websites, one of the USGS [14] and one by John Louie [15], who provide audified seismograms for educational purpose.

## **1. AUDITORY SEISMOLOGY: STATUS QUO**

As presented in last year's ICAD conference my own interest in "Auditory Seismology" is mostly qualitative. I use audification to get an overview of the underground's activity and stress situation, and focus especially on temporal developments. Motivated by philosophical and psychological descriptions of the ear as being explicitly attentive to hear for coming events I am driven by the hope that in the long run Auditory Seismology will provide important insights in the area of earthquake warning and prediction research. To approach this goal the following steps have been made:

A unified acceleration method has been developed to make the compatibility between different records possible (cf. chapt. 3). Familiarizing with the earth's sounds apparently needs time and it takes a while until we are able to orientate in the new soundscape. Several comparative studies have been made to reidentify geophysical categories within audified data: Discriminating a signal from its background noise by listening proved to be easy. The background noise which is influenced by ocean waves, weather, human activity like car traffic etc. cumulates in a more or less steady noisy chirping sound (changing with daytimes etc.), whereas the actual earthquake makes itself heard as an distinct tap or thump. A tectonic region shows an overall acoustic

similarity of quakes even though each event has some special sound characteristics. Relative loudness depends on the magnitude and distance of the earthquake. The timbre is strongly influenced by the site-response of the station: materials in the underground like sediments sound more metal-like, bedrocks more wooden. The distance between epicenter and station causes dispersion, i.e. at long range the signal broadens due to complex phase velocities (cf. elastodynamic Green's function). One encouraging result from the last publication was the apparent ability to discriminate between different tectonic source mechanisms. Earthquakes from subduction zones (i. e. one plate subducts the other) sound obviously different from mid ocean ridges (i. e. two plate margins part from each other). Where the first is like a sharp hard beat, the second sounds like a plop. Shear zones relate in sound to subduction zones but characteristically produce a whole little series of minor and major beats during an earthquake. This result encouraged me to go into more detail of source mechanisms (cf. chapt. 4).

## **1. METHOD: AUDIFYING SEISMOGRAMS**

The main instrument in seismology is the seismometer which registers the earth's movement at its surface. The received signals range usually from 20 Hz down to about 0,3 mHz which are not audible. Signals of more than 20 Hz (i. e. audible earthquake sounds) arise only very rarely as it is described above. To open the ear also for the low frequencies of the earth's oscillation seismic waveform data needs to be audified. Therefore to accomodate this, the seismogram is time-compressed and its amplitude signal played on a speaker. The outcome is a mixture ground noise and incoming events of different amplitude.

The character of the audified signal is influenced by the compression method. I usually work with linear compression to keep the signal's characteristic. But this approach has some limitations which need to be kept in mind: Seismic signals can have a frequency spectrum up to 17 octaves from which linear transformation can only display up to 10. So far I use factor 2.200 as a standard time-compression and in cases where more detailed information is needed a factor of 1.100. From my experience this frame of the spectrum seems to provide most of the signal's crucial information.

Another limitation is found in the dynamic range of seismic and audio signals. In seismology registration is done with 24 bit, sometimes even 32 bit, to get full resolution for background noise as well as high magnitude earthquakes. To transform the seismic signal to the audio range, a reduction to 16 bit has to be done. I use normalization in cases where I focus upon the sound of one event, and apply an automatic gain control when noise and signal shall both be hearable; e. g. when listening to several day-registrations.

Furthermore one has to be aware that acoustic waves are air waves (1-dimensional) whereas seismic waves are body waves (3-dimensional). Audified seismograms can therefore display only one component of a 3-dimensional

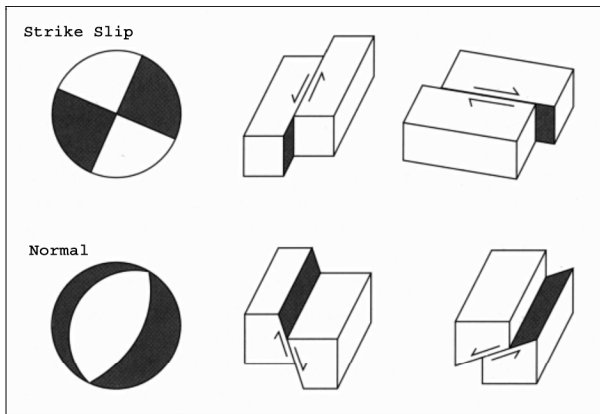

Figure 1a: Source mechanisms: the focal spheres and their corresponding fault geometries. The compressional quadrant is shaded.

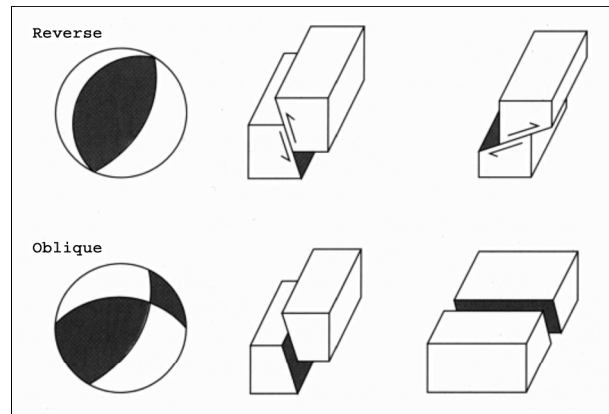

Figure 1b: Both Figures 1a and 1b are taken from P. M. Shearer: *Introduction to Seismology*, Cambridge 1999, p. 176.

registration, which in seismology usually is: north-south (horizontal), east-west (horizontal), and z (vertical). Doing some tests I found that surprisingly the acoustic characteristics of the three components differ much less than the visual. In the examples I listened to I could not trace any dramatic change in sound between the three components. So I became convinced that using only one component should serve for further investigations. I chose the vertical z-component as a reference, arguing that if the surface of the earth functions as a speaker's membrane, it is the z-component that produces the sound.

The seismic data has been so far transformed into audio format by a set of mock-up computer routines written in C. This approach has now become too time consuming and presently does not operate comfortably. So we decided to work with MAX/MSP audio software (originally developed by IRCAM Paris) to open Auditory Seismology to a whole range of acoustic investigations. We have started to integrate extensions for the import of seismic data to feed earthquake signals directly into a real time DSP programming environment.

## 1. RESULTS

Further investigations in Auditory Seismology gave insight into the following aspects of audified seismic signals:

(i) Free Oscillations: Really big earthquakes are able to make the whole earth 'ring like a bell'. This phenomenon - so called free oscillations - has on the planet earth a ground mode of about 1 h period, and spheroidal and toroidal modes of higher frequencies. Its appearance can be acoustically identified when audifying seismic registrations. The hit of the quake resonates and several reverbs can be heard from any point of the globe. The acoustic impression is especially apparent when using a higher compression factor of 10.000 times instead of our usual reference factor 2.200.

(ii) Depth: Tectonic earthquakes happen in the crust and are usually related to tectonic margins. As the crust is rarely thicker than 60 km one would expect no quakes to happen deeper than 60 km, which proves not to be the case. There are areas where hypocenters are observed ranging in depths down to 670 km. The common

explanation for deep-focus earthquakes is that an oceanic plate is subducting a continental plate, and dipping down into the mantle, slowly melting under the high temperature and pressure conditions. These changing conditions surprisingly have no effect on the sound characteristics of an earthquake. I tested a series of quakes with different depths and could not trace any change in the acoustic characteristics. This seems to support the geophysical theory of olivine-spinel phase transition, where the phase transformation is assumed not to influence earthquake wave characteristics.

(iii) Tectonics: The general classification of tectonic areas (spreading ridges, subduction zones, shear zones) were identified in audified earthquake signals (cf. [9]). I have now studied this aspect in more detail at different fault geometries and concentrated on the classification of focal mechanisms (shown by centroid moment tensor solutions (CMT), usually displayed in so called 'beach ball diagrams'. Cf. Fig. 1 a & b). The first results show that different sounds relate to different CMT solutions. Now I am testing in the opposite direction, to see if each CMT class produces similarly the same sound-type, independent from the tectonic area.

(iv) Day Series: Driven by the goal of getting inspiration for earthquake warning and prediction research, I audified a series of day registrations before and after major quakes. Herewith I tried to train my ear for estimating the influence of foreshocks and triggering distant quakes. Kobe earthquake of 1995 has such a distant quake series from Rat Islands (Aleutian Islands) coming in only 2 hours earlier. From the acoustic point of view a relation seems possible but cannot be confirmed geophysically yet. Prediction or warning is still an open question.

Two more aspects seem to be noteworthy:

(v) Explosions: The first proposition for audifying seismic data was given by Speeth [4] with the goal to discriminate between natural events and atomic explosions. I audified some registrations of those events and confirmed the theses of Speeth, insofar that I also could not find an obvious acoustic clue. The explosions sound more or less like earthquakes at intercontinental plate margins, and discriminating between these two is not easy.

(vi) Synthetic Seismograms: In seismology complex registrations are often purified for mathematical calculation. The seismogram is then visually compared with a synthetic one to see how well the mathematical description of a focus fits with reality. I audified a number of registrations to listen to how common filtering methods influence the signal. Comparing the original registration with the filtered signal and the related synthetic seismogram it became apparent that filtered and synthetic seismograms are of low interest for Auditory Seismology. The filters clean the seismogram visually but at the same time the audified sound loses its substance. Scattered and reflected waves are missing and herewith the earthquake's characteristics become almost unrecognizable. In my opinion it is not very worthwhile to listen and study synthetic seismograms much further. Or maybe it would be interesting to design new mathematical routines for calculating seismograms that approach the original signal under acoustic viewpoint. This might give new insight into the propagation of earthquake waves underground.

## 2. CONCLUSIONS

It is of interest to listen to the complex acoustic surrounding that is provided by Auditory Seismology. The reported results demonstrate, that eyes and ears give access to different aspects of the phenomenon of earthquakes. Free oscillations are relatively easy to recognize as the ear is all too familiar with many kinds of resonance. On the other hand synthetic seismograms, which are calculated for fitting as good as possible the curve of a measured seismogram, show low significance in the auditory display. This is less astonishing if one remembers that the power of calculation routines has been judged only by the visual correspondence of measured and synthetic seismogram.

Furthermore, focal mechanisms have been investigated: deep-focus earthquakes differ not from shallow events; tectonic mechanisms can be acoustically recognised; triggering quakes seem to be of interest for prediction research; explosions are difficult to discriminate from natural events. For the future more work is needed. Only slowly the ear accustoms to orientate acoustically in the underground (and 2000 years of visual primat cannot be overcome so fast). To improve the qualitative research more seismic stationers and seismologists need to be involved who are closely familiar with the data. Investigation has to specialise into specific regions to study an area in more detail, and integrate the know-how of data collectors. One should think also about carrying out user tests to quantify the results.

## 3. ACKNOWLEDGEMENTS

The seismological data used were provided by IRIS data center in Seattle, Washington, and ORFEUS data center in De Bilt, Netherlands. The synthetic seismograms (earthquake of Kobe 1995) were calculated by Frank Krüger, University of Potsdam. Some of the free

oscillation data was kindly given to me by Thomas Jahr from University of Jena. And last not least I would also like to thank my colleague Gerhard Eckel from IMK for his continuous support.

## 4. REFERENCES

- [1] K. V. Steinbrugge, "A Catalog of Earthquake Related Sounds," in *Bull. seism. Soc. Am.*, vol. 64, 1974, pp. 1409-1417.
- [2] R. M. Rilke, "Ur-Geräusch," in *Sämtliche Werke*, vol. 6, Insel, Frankfurt a. M., 1987, pp. 1085-1093.
- [3] J. Dewey and P. Byerly, "The Early History of Seismometry (to 1900)," in *Bull. seism. Soc. Am.*, vol. 59, 1969, pp. 183-227.
- [4] S. D. Speeth, "Seismometer Sounds", in *J. Acoust. Soc. Am.*, vol. 33, 1961, pp. 909-916.
- [5] G. E. Frantti and L. A. Leverault, "Auditory Discrimination of Seismic Signals from Earthquakes and Explosions," in *Bull. seism. Soc. Am.*, vol. 55, 1965, pp. 1-25.
- [6] C. Hayward, "Listening to the Earth Sing", in G. Kramer (ed.), *Auditory Display. Sonification, Audification, and Auditory Interfaces*. Addison-Wesley, Reading, USA, 1994, pp. 369-404.
- [7] Kookoon: *Inner Earth. A seismosonic symphony*. Traumton, Berlin, 1999 (CD by W. Loos and F. Scherbaum).
- [8] F. Dombois, *Über Erdbeben. Ein Versuch zur Erweiterung seismologischer Darstellungsweisen*, Diss., Berlin, Humboldt-University, 1998 [<http://dochostrz.hu-berlin.de/listen/dissertationen/geophysik-liste.html>].
- [9] F. Dombois, "Using Audification in Planetary Seismology," in *Proc. 2001 Int. Conf. Aud. Displ. (ICAD)*, Helsinki, July 2001, pp. 227-230
- [10] F. Dombois, "Listen to Seismograms. About Acoustic Interpretation of Seismometric Records", in *Geophysical Research Abstracts*, vol. 3, 2001, p. 982.
- [11] F. Dombois, "Underground Sounds. An Approach to Earthquake Prediction by Auditory Seismology," in *Geophysical Research Abstracts*, vol. 4, 2002, EGS02-A-02741.
- [12] A. Cellini, M. Mariotti and F. Nucera, "Fonostimologia, un approccio nuovo per l'analisi sismica", in *ARS*, vol. 73 (March/ April), 2000, pp. 22-24.
- [13] <http://www.gmd.de/projects/auditory-seismology>
- [14] <http://quake.wr.usgs.gov/info/listen/>
- [15] <http://www.seismo.unr.edu/ftp/pub/louie/sounds/>